

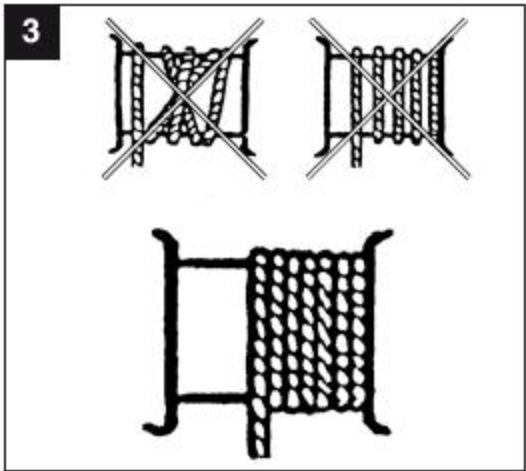

WARRIOR MINI ELECTRIC HOIST

Operating Instructions

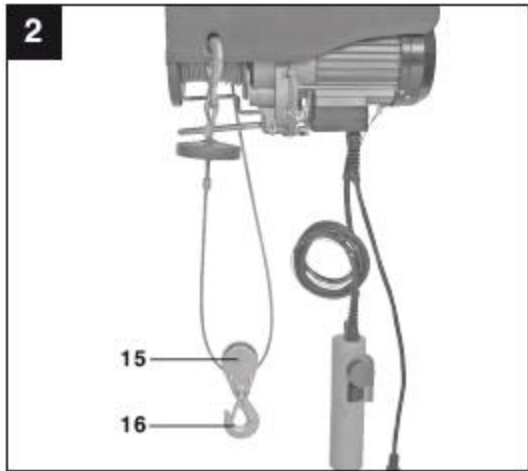

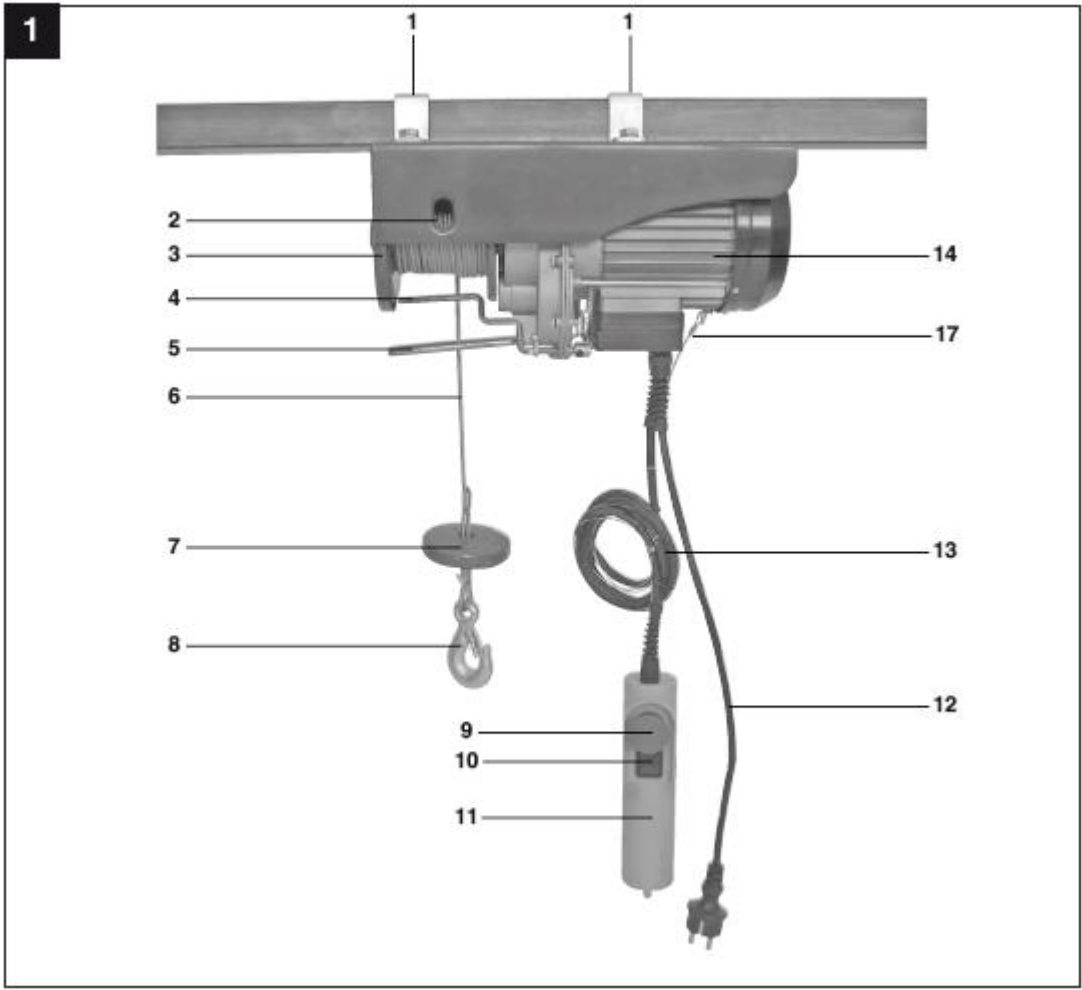

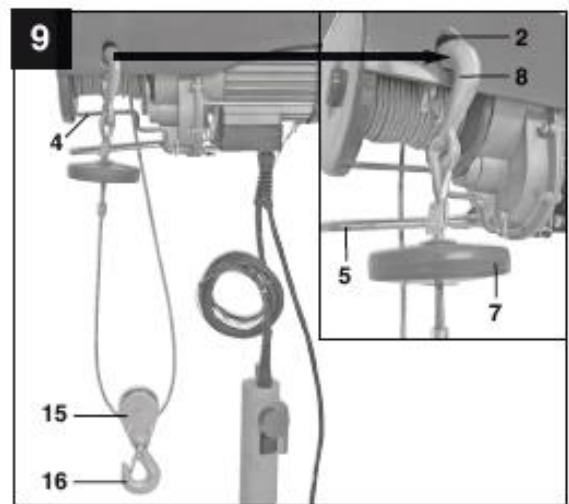
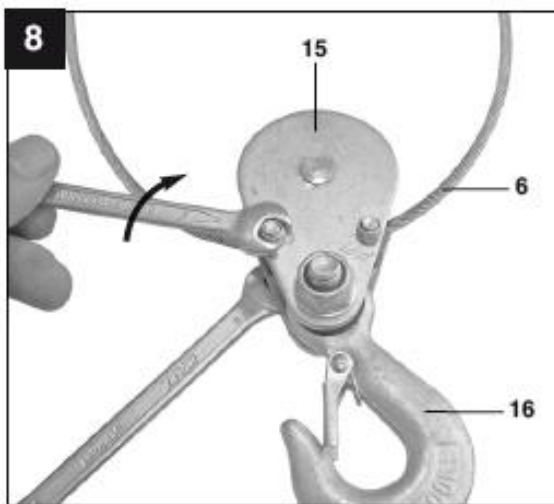
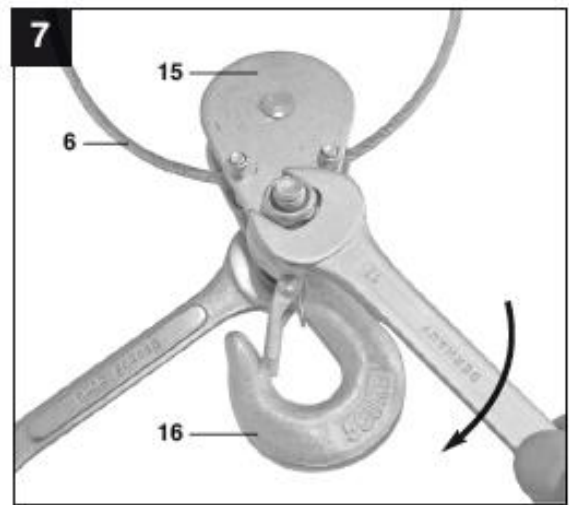
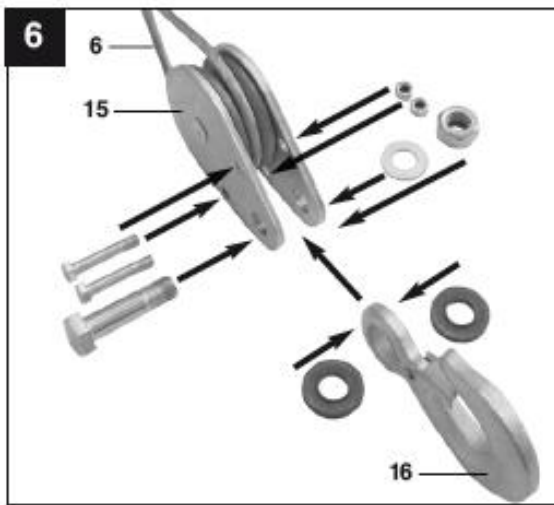
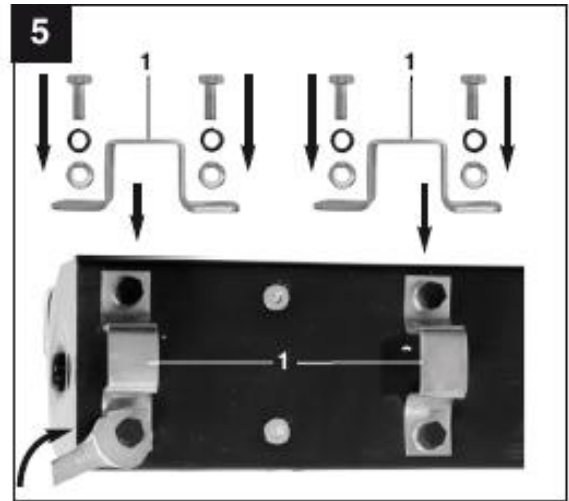
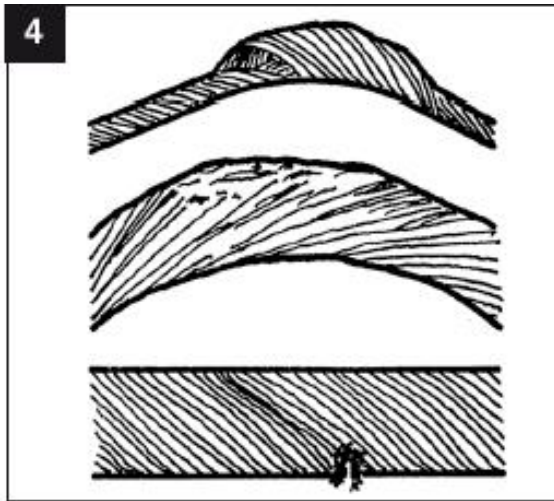

_ Danger!

When using the equipment, a number of safety precautions must be observed to avoid injuries and damage. Please read the complete operating manual with due care. Keep these operating instructions in a safe place so that the information is available at all times. If you give the equipment to any other person, provide them with training on how to operate the equipment properly and give them these operating instructions as well. We cannot accept any liability for damage or accidents which arise due to failure to follow these instructions and the safety information.

1. Safety regulations

_ DANGER!

Read all safety regulations and instructions.

Any errors made in following the safety regulations and instructions may result in an electric shock, fire and/or serious injury.

Keep all safety regulations and instructions in a safe place for future use.

1. Always check that the mains voltage is identical to the voltage quoted on the rating plate. In the event that the mains voltage is not suitable, it may cause the machine to work abnormally and thus result in personal injury.
2. The power supply must be earthed and be secured by a residual current operated circuit breaker (RCCB).
3. Do not attempt to lift loads that exceed the rated load.
4. Use the machine only for the purpose for which it is designed. Never lift personnel using the cable hoist.
5. Do not pull the power cable in order to pull out the plug. Protect the power cable from heat, oil and sharp edges.
6. Never attempt to raise fixed or jammed loads.
7. Pull out the plug when the cable hoist is not in use.
8. Keep children and other unauthorized persons away from the machine.
9. Do not pull loads sideways or from one side. Do not allow the load to swing.
10. Ensure that the hook moves in the same direction as shown on the control switch.
11. Check the cable hoist at regular intervals for signs of damage. The control switch must be in good condition.
12. Do not switch the machine on and off quickly (inching mode).
13. Always concentrate fully when operating the cable hoist.
14. Do not stand or work under the raised load.

2. Layout (Fig. 1-2)

1. Fastening bar
2. Fastening hole for hook
3. Drum
4. Lever for maximum cable length
5. Automatic stop mechanism lever
6. Steel cable
7. Cut-out weight
8. Hook
9. Emergency Stop switch
10. Pushbutton
11. Remote control
12. Power cable
13. Control cable
14. Motor
15. Return roller
16. Additional hook
17. Cable for remote control

3. Scope of delivery

- Open the package and take the unit to the out carefully from the packaging.
- Remove the packing material as are Packaging and transport safety (if any).
- Check whether the delivery is complete.
- Check that the device and its accessories are not damaged by transport.
- Keep the packaging as much as possible until the end of the warranty period.

Danger!

The appliance and packaging material are not toys! It is forbidden to leave children play with plastic bags and films with small parts. They risk swallow and choke! No original job Fashion

4. Proper use

The cable hoist is designed for lifting and lowering loads in enclosed areas commensurate with the machine's capacity.

The equipment is to be used only for its prescribed purpose. Any other use is deemed to be a case of misuse. The user / operator and not the manufacturer will be liable for any damage or injuries of any kind caused as a result of this.

Please note that our equipment has not been designed for use in commercial, trade or industrial applications. Our warranty will be voided if the machine is used in commercial, trade or industrial businesses or for equivalent purposes.

5. Technical data

Type	141275	141277	141278	141279	141280
Rated voltage	230v~	230v~	230v~	230v~	230v~
Rated frequency	50 Hz	50 Hz	50 Hz	50 Hz	50 Hz
Power rating:	500W	1000W	1000W	1300W	1300W
Rated current	2.18 A	4 .35A	4 .35A	5.6A	5.6A
Max. loading capacity -for single cable -for double cable	100 kg 200 kg	200 kg 400 kg	300 kg 600 kg	400 kg 800 kg	500 kg 999kg
Cable speed -for single cable -For double cable	8m/min 4m/min	8m/min 4m/min	8m/min 4m/min	9m/min 4.5m/min	8m/min 4m/min
Hoisting height -for single cable -For double cable	12 m 6 m	12 m 6 m	12 m 6 m	12 m 6 m	12 m 6 m
Cable diameter	3,0 mm	4.0mm	4,5 mm	5,0mm	6,0 mm
Protection rating	IP54	IP54	IP54	IP54	IP54
Motor category	M1	M1	M1	M1	M1
Work duty	S3 20%- 10min	S3 20- 10min	S3 20%- 10min	S3 20%- 10min	S3 20%- 10min
Protection rating	I	I	I	I	I
Weight	10.4 kg	16.5kg	17.0kg	19.0kg	25.0.kg
Sound pressure level (LWA)	71 dB(A)	71 dB(A)	71 dB(A)	71 dB(A)	71 dB(A)

Operating mode S3 – 20% - 10 minutes: S3 = Intermittent mode without influencing the starting process. This means that the maximum operating period over a time of 10 minutes is 20% (2.0 minutes).

- Only use appliances which are in perfect working order.
- Service and clean the appliance regularly.
- Adapt your working style to suit the appliance.
- Do not overload the appliance.
- Have the appliance serviced whenever necessary.
- Switch the appliance off when it is not in use.
- Wear protective gloves.

6. Before starting the equipment

Danger!

- _ Before you connect the equipment to the mains supply make sure that the data on the rating plate are identical to the mains data.
- _ Always pull out the power plug before making adjustments to the equipment.
- _ The cable hoist is not suitable for transporting hot and/or molten masses and in addition it is not suitable for use at low temperatures or in aggressive atmospheres.
- _ It is in mechanical group M1.
- _ The service life of the cable hoist is approximately 8000 cycles (excluding wearing parts). When the hoist has completed 8000 cycles, all its mechanical parts must be checked and overhauled.
- _ Read and absorb the operating instructions before you use the cable hoist.
- _ Ensure that the operator knows how the machine works and how it should be operated.
- _ The user should always operate as set out in the operating instructions.
- _ The cable hoist is not designed for continuous operation. Its mode of operation is: Intermittent mode without influencing the starting process.
- _ The rated capacity of the machine does not vary due to the position of the load.

6.1 Unpacking

After opening the packaging, inspect the frame, the steel cable, the hook and the electric control mechanism for signs of possible transit damage.

6.2 Assembly (Fig. 5)

The cable hoist is fitted with two fastening bars (1) with which it has to be fastened to a rectangular tube. The dimensions of the arm must conform with the size of the fastening bars (1) and must be capable of supporting twice the rated load. We recommend that you seek advice from a qualified technician.

All screws must be tightened correctly. A qualified technician should check the anchoring of the arm before the machine is started.

6.3 Block and tackle function (Fig. 6 – 9)

The cable hoist is fitted with a return roller (15)

and an additional hook (16). If these parts are used correctly, the cable hoist can lift twice its rated load. Fit the return roller (15) and additional hook (16) as shown in Figure 6 – 8. The permanent hook (8) must be attached to the fastening hole (2) (Fig. 9). The load is now raised by two steel cables, which means that the cable hoist can lift twice its rated load.

7. Operation

7.1 Information for operation

1. Remove the adhesive tape from the drum (3) before using the hoist for the first time.
2. The value of the A-rated noise emissions at the operator's position is less than 75 dB.
3. Supply voltage: 230 V \pm 10%, 50 Hz \pm 1%.
4. The cable hoist must be operated in ambient temperatures of between 0°C and 40°C with a relative humidity of less than 85%. Height above sea level: max. 1,000 m.
5. The temperature for transport and storage may be between -25°C and 55°C. The maximum temperature must not exceed 70°C.
6. The user should lift the load off the ground at the slowest possible speed. The cable should be taut when the load is raised.
7. The motor (14) for the cable hoist is fitted with a thermostat switch. Whilst the cable hoist is operating, the motor (14) may therefore stop. It will restart automatically when it has cooled down.
8. The electric cable hoist is not fitted with a rated power limiter. You should therefore not repeat attempts to lift a load if the overload trip is limiting the hoist's operation. In this case the load exceeds the rated capacity of the cable hoist.
9. Do not leave any suspended loads unsupervised without first taking the appropriate safety precautions.
10. Fit the machine with a 10 A fuse or a 10 A residual current operated circuit breaker (RCCB) to protect the circuit
11. Do not use the lever (4/5) as a routine stopping device. It should only be used to stop the machine in an emergency.

12. Before you start, ensure that the steel cable (6) is correctly wound around the drum (3) and that the spacing between the windings is smaller than the steel cable (Fig. 3)

13. Ensure that the load is correctly secured to the hook (8) or, if you are using the block and tackle, the additional hook (16) and always maintain a safe distance from the load and the steel cable (6).

7.2 Operation (Fig. 1)

_ Check whether the Emergency Stop switch (9) is pressed. Turn the red stop switch clockwise to release it.

_ Press the pushbutton ▲ (10) to raise the load.

_ Press the pushbutton ▼ (10) to lower the load.

_ Automatic stop mechanism lever (5): When the maximum lifting height has been reached, the cut-out weight (7) presses the lever (5) upwards. This trips a limit switch after which the load cannot be raised any further.

_ Lever for maximum cable length (4): When the load has reached its lowest possible position, a limit switch is tripped which makes it impossible to lower the load any further. This limit switch also prevents the cable hoist operating in the wrong direction (hook moving in the opposite direction to the arrow shown on the control switch).

_ The cable hoist will stop if the Emergency Stop switch (9) is pressed.

_ In an emergency, immediately press the Emergency Stop switch (9) to stop the cable hoist. The cable hoist cannot be operated if the Emergency Stop switch has been pressed.

8. Cleaning, maintenance and ordering of spare parts

Danger!

Always pull out the mains power plug before starting any cleaning work.

8.1 Cleaning

- Keep all safety devices, air vents and the motor housing free of dirt and dust as far as possible. Wipe the equipment with a clean cloth or blow it with compressed air at low pressure.
- We recommend that you clean the device

immediately each time you have finished using it.

- Clean the equipment regularly with a moist cloth and some soft soap. Do not use cleaning agents or solvents; these could attack the plastic parts of the equipment. Ensure that no water can seep into the device.

8.2 Servicing

Important. Always ensure that the machine is not connected to the mains supply before you start any servicing work.

_ In the following: One cycle means one raising and lowering movement of a load. Periodic inspection means an inspection after 100 cycles.

_ Test periodically that the limit switches on the cable hoist are in correct working order. Conduct this test as follows: When the cable has reached the maximum height, the lever on the automatic stopping mechanism (5) will be actuated. The motor (14) must then stop. (Test without a load). When the steel cable (6) has been unwound as far as possible, the lever for the maximum cable length (4) will be actuated. The motor (14) must then stop.

_ Inspect the mains cable (12) and the control cable (13) periodically.

_ The steel cable (6) and return roller (15) must be greased every 200 cycles.

_ A check must be made every 30 cycles, as shown in Fig. 4, to find whether the entire steel cable (6) is in good condition. If it is damaged, it must be replaced by a steel cable of the type specified in the technical data.

_ Check every 1000 cycles whether the screws for the fastening bars (1) and return roller (15) are properly tightened.

_ Check every 1000 cycles whether the hooks (8/16) and return roller (15) are in good condition.

_ Lubricate the cable, chain, gear unit, bearings and hooks regularly.

_ Check wearing parts after every 1000 cycles, e.g.: cable, chain, hooks, belts and brake linings.

_ Check before using the cable hoist whether the Emergency Stop switch (9) and pushbuttons (10) are in perfect working order.

_ Check the braking system every 1000 cycles. If the motor (14) makes any unusual noises or cannot raise the rated load, it is possible that the braking system requires an overhaul:

- Replace damaged or worn parts and keep the service documentation relating to this in a safe place.

- Please contact an authorized service center for any unscheduled maintenance work.

_ Have your electric tools repaired only by a qualified electrician.

9. Storage

Store the equipment and accessories out of children's reach in a dark and dry place at above freezing temperature. The ideal storage temperature is between 5 and 30 °C. Store the electric tool in its original packaging.

10. Disposal and recycling

The unit is supplied in packaging to prevent its being damaged in transit. This packaging is raw material and can therefore be reused or can be returned to the raw material system.